

# FRONT MOUNT CYLINDER SEAL KIT, HS5157 & HS5167

Use Seal Kit #HS5157 and #HS5167 with:

Front Mount Cylinders Part#'s

**HC5340, HC5341, HC5342, HC5343, HC5344, HC5345, HC5346, HC5347, HC5348, HC5358, HC5365, HC5375, HC5394, HC5445, HC6750, HC6751, HC6752, HC6753, HC6754 & HC6755.**

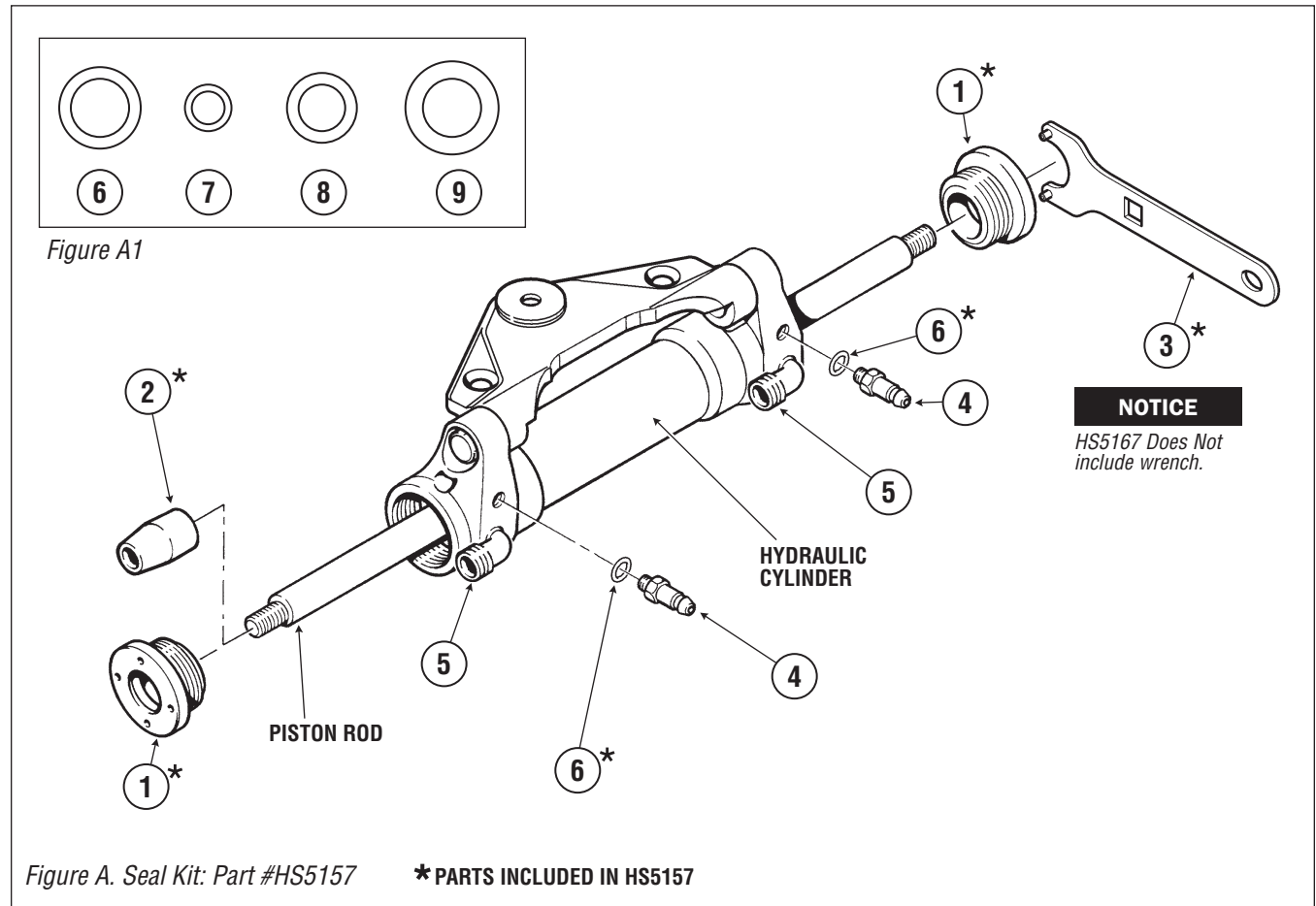

ITEM	PART#	QTY	DESCRIPTION
1	797021	2	Seal Gland Only
2	745920	1	Seal Gland Assembly Guide Tool
3	745525	1	Pin Wrench Only
4	HF5548	1	Pair of Bleed Nipples & O' Rings
5	600601	1	Elbow Fitting
6	015824	2	'O' Ring, .011, 70 DUR N

ITEM	PART#	QTY	DESCRIPTION
<b>NOTICE</b> Seals (Items 7, 8 and 9) are for use with cylinders HC5340-42 and HC5365. Refer to figure A1, figure B and figure D.			
7	224026	2	'O' Ring, .165, 70 DUR
8	002222	2	'O' Ring, .010, 70 DUR
9	222228	2	'O' Ring, .109, 70 DUR N

Carefully inspect the piston rod for any sign of scratches, nicks or burrs. If the shaft is damaged in any way, the complete steering cylinder must be replaced. Failure to replace a damaged steering cylinder will result in seal failure and possible loss of steering.

**To replace a screw-in type end gland, proceed as follows:**

**⚠ WARNING**

**Do not remove shaft from Steering Cylinder. Permanent damage may occur resulting in a total loss of steering.**

1. To remove the port side gland, turn the steering wheel to the hard-over port position, for the starboard gland turn the wheel to hard-over starboard. This will locate the cylinder rod piston at the defective gland end and minimize the amount of oil that will leak out when the gland is removed.
2. Place the pin wrench provided in the holes of the gland. Use a 5/8" box-end wrench to hold the cylinder rod nut that is on the same side of the engine as the gland. See *Figure B, C or D depending on cylinder model*.
3. If you are replacing the port gland, refer to *Figure B, C or D depending on cylinder model* and proceed as follows:
  - turn the steering wheel to the hard-over port position,
  - place the pin wrench in the port gland holes,
  - use the box-end wrench on the port side piston rod nut,
  - push down on the pin wrench, hold up on the box-end.

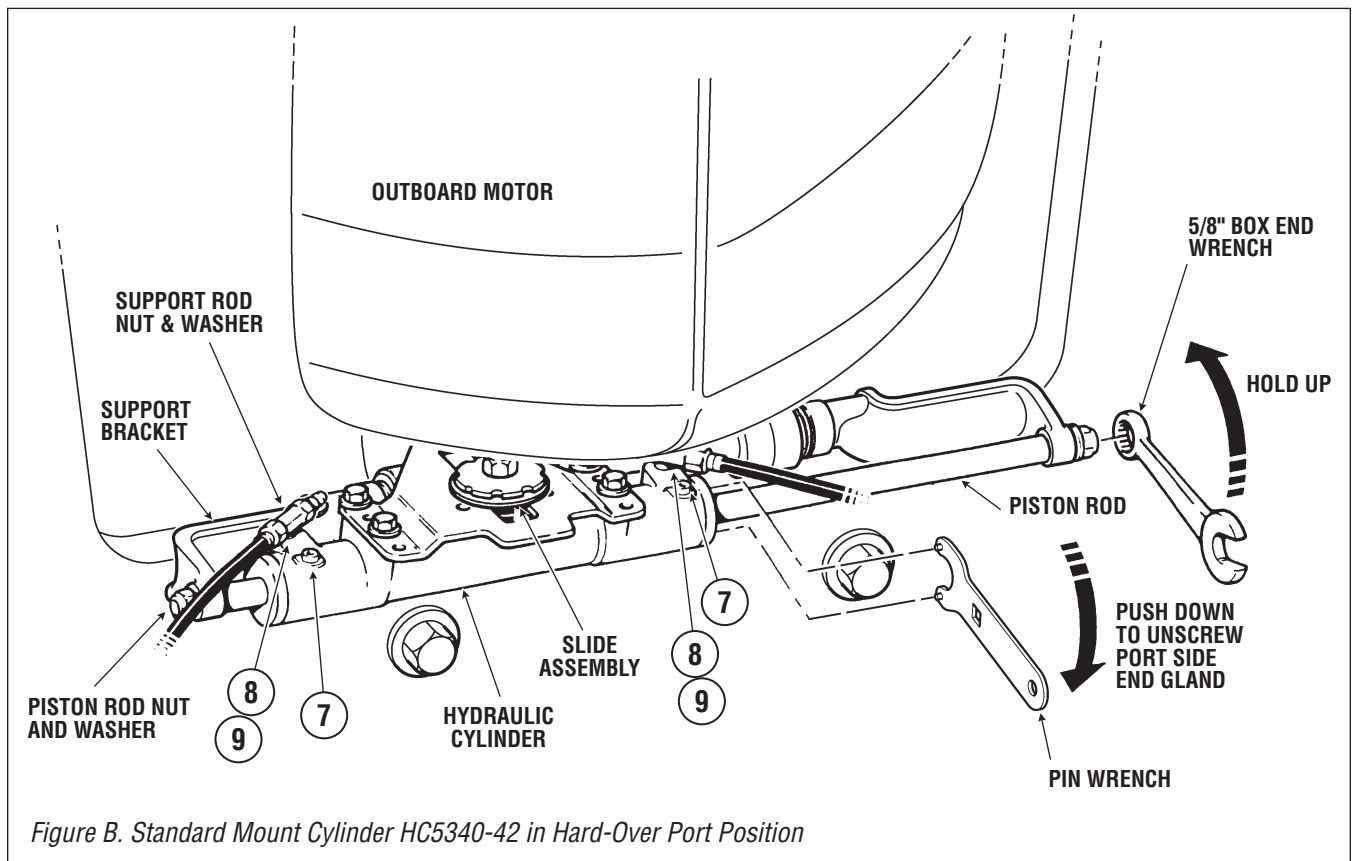

Figure B. Standard Mount Cylinder HC5340-42 in Hard-Over Port Position

**⚠ CAUTION**

The oil will stain your clothing.

**⚠ WARNING**

Do not substitute the self-locking nuts with non-locking nuts or loss of steering may occur, causing property damage and/or personal injury.

4. Remove the piston rod nut and washer, and the 1/2" support rod nut (3/4" wrench) and washer. Use a wrench on the opposite nut to keep the rod from rotating. Remove the support bracket.
5. Unscrew and slide the gland off the piston rod. A small amount of oil will leak out.
6. Place the gland seal guide onto the cylinder rod as shown in Figure A, and lubricate with oil or grease.
7. Slide gland over seal guide and screw into the cylinder; do not tighten yet.
8. Reconnect the support brackets, washers and nuts.
9. Tighten both the 1/2" support rod nut and the piston rod nuts against their washers.
10. Insert the pin wrench in the new gland and use the 5/8" box-end wrench on the piston rod nut that is on the opposite side of the cylinder.
11. Tighten the new gland to 50 ft/lbs torque, counteracting this torque with the box-end wrench.
12. If the starboard gland is to be replaced, turn the steering wheel to the hard-over starboard position and repeat steps 1 – 11 for the opposite side, reversing the procedure in step 1.

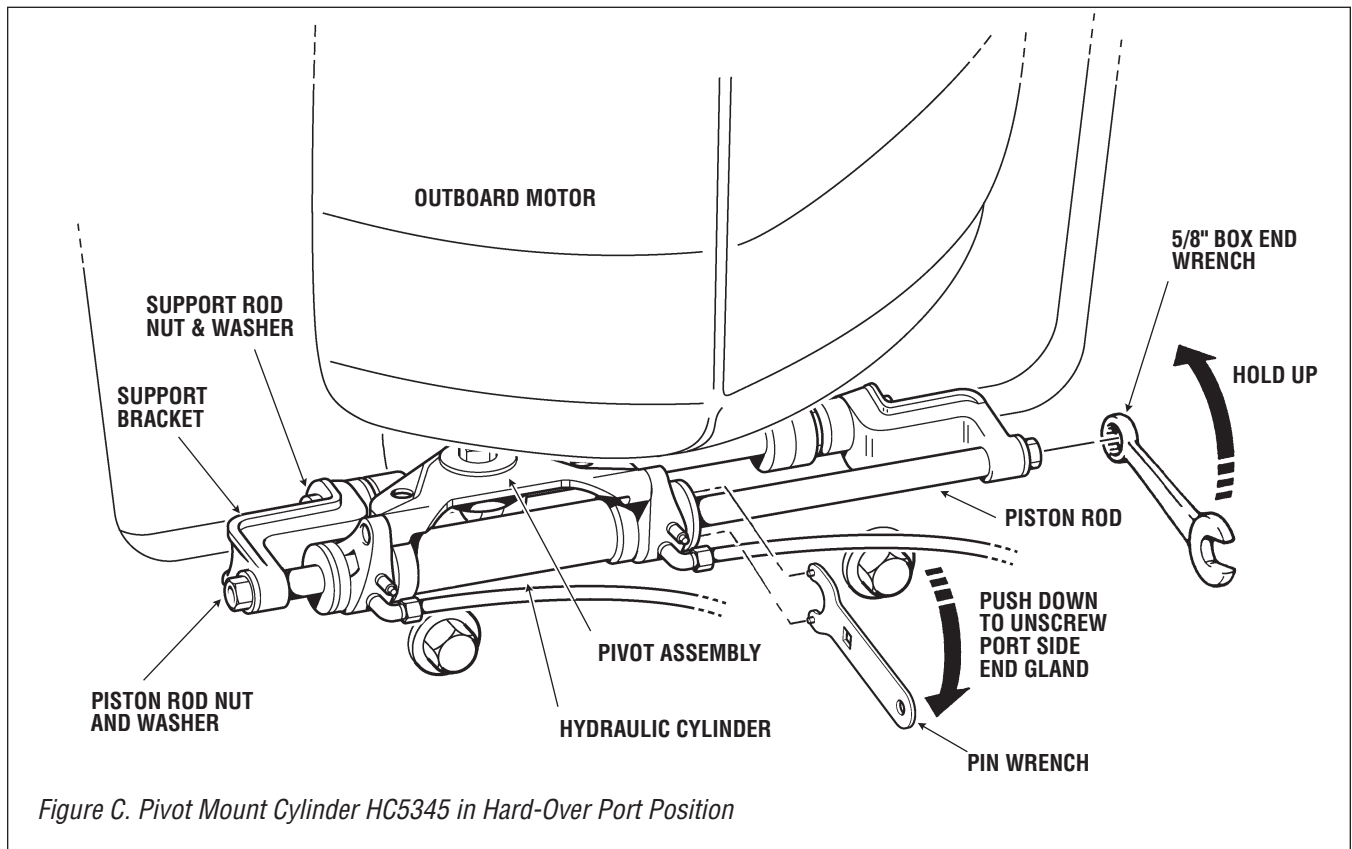

Figure C. Pivot Mount Cylinder HC5345 in Hard-Over Port Position

**⚠ WARNING**

**Hydraulic Hoses should be protected from chafing and should be secured wherever possible. Continuous kinking, chafing or rubbing may eventually weaken hose(s) to a point where it could rupture from normal steering pressure, causing loss of steering, resulting in damage to boat and/or personal injury.**

13. Bleed the cylinder to remove any air in the system; you will need additional hydraulic oil, (Teleflex part no. HA5430). Follow the fill and purge directions in the "Teleflex Installation Instructions and Owner's Manual".
14. Check for smooth operation and full travel of the cylinder.
15. System Check for possible leaks and air removal. Turn Steering wheel (any one on a multi-steering station) to the port side hard over position. Apply enough force to the wheel to exceed pressure relief. You will hear a squealing sound and the steering wheel should slip. While pressure is being maintained on the wheel, check all fittings and line connections as well as new end glands for leaks. Repeat procedure by turning to the starboard side. If any leaks are found they should be corrected prior to using the system. Failure to do so will lower oil level and may result in a loss of steering. If no leaks are obvious your steering system is ready for use.

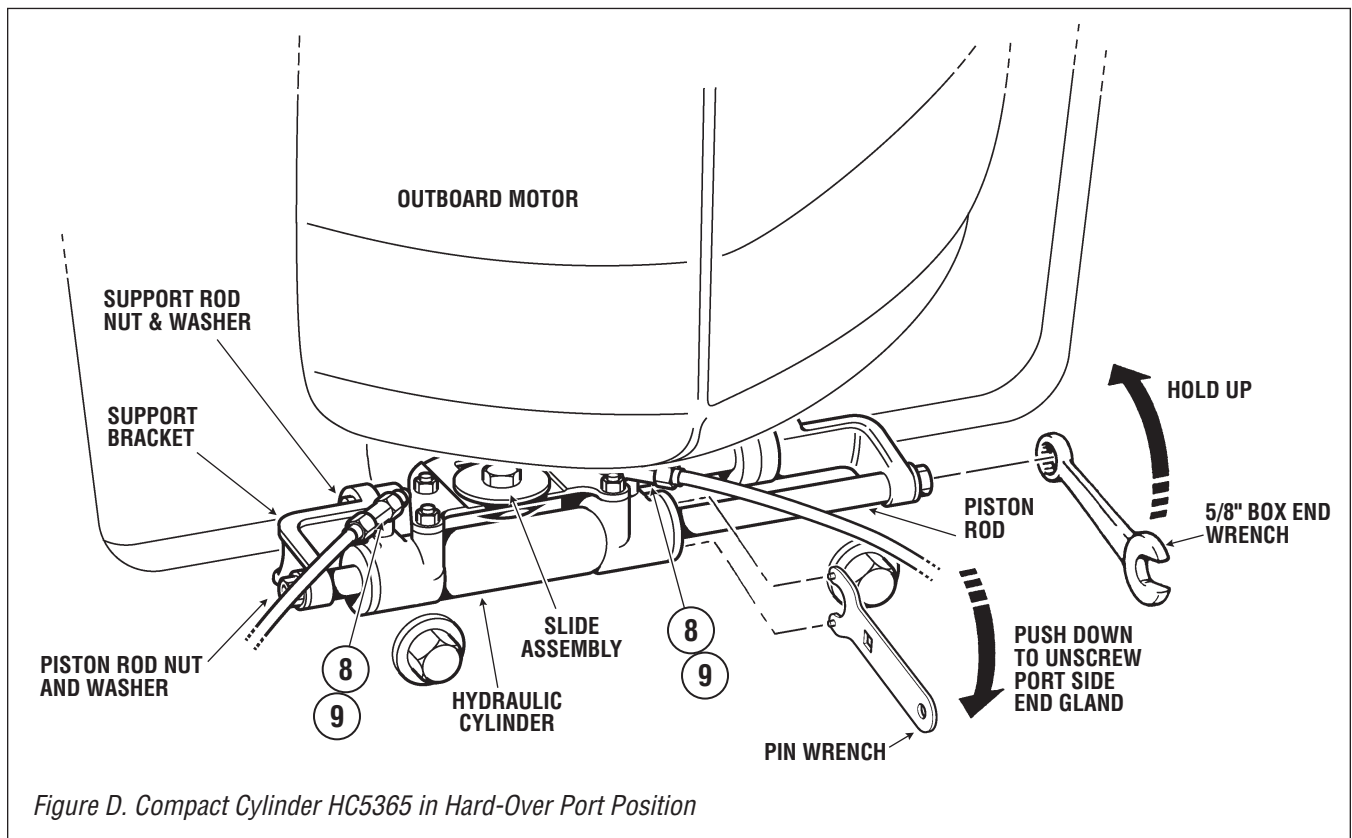

Figure D. Compact Cylinder HC5365 in Hard-Over Port Position