



POSITIONAL O-RING HORIZONTAL & VERTICAL TEE FITTING INSTALLATION/REALIGNMENT

Cylinder Fitting Installation (If required.)

- 1 Back off lock nut (item 1), counter-clockwise, until it stops.
- 2 Thread fitting into cylinder body until fitting washer (item 2) contacts the face of the cylinder port. Tighten hand tight, DO NOT TORQUE FITTING INTO GLAND.
- 3 Position fitting to desired orientation by turning it counter-clockwise to a MAXIMUM of 1 full turn.
- 4 While holding fitting with a wrench, tighten the locknut (item 1) and torque to 40–43 ft-lb.
- 5 Purge system as per your cylinder instruction manual.

⚠ WARNING

Failure to properly tighten the locknut (item 1) may lead to loss of steering control. Loss of steering control may result in unpredictable boat behavior, collision with an obstacle and/or ejection from vessel, leading to property damage, personal injury and/or death.

⚠ WARNING

Teleflex recommends that the hose and hose fittings are checked on a regular basis to ensure the safe operation of the steering system.

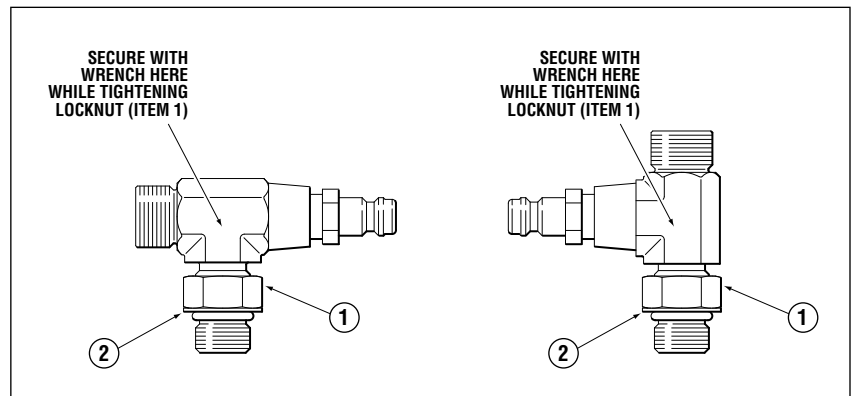

Figure A.

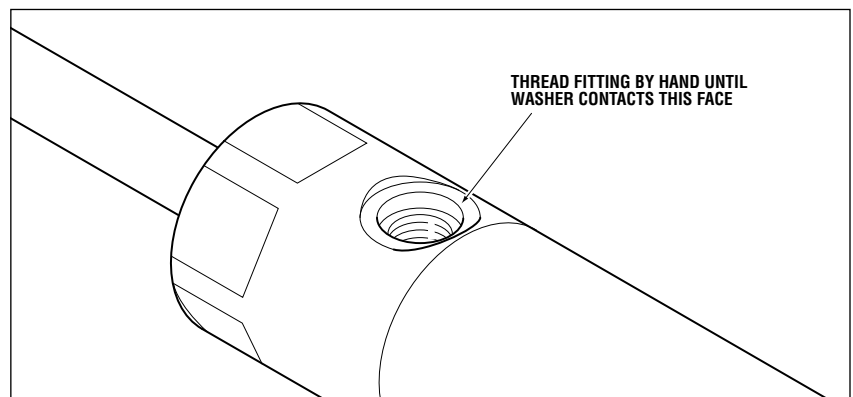

Figure B.