

CATAMARAN

Outboard Steering System

HORSEPOWER LIMITATIONS

ENGINE CONFIGURATIONS	MAXIMUM HORSEPOWER	CYLINDER	RECOMMENDED HELM PUMP	NO. OF STEERING WHEEL TURNS
NON COUNTER-ROTATING	UP TO 450HP	HC5343	HH5271	5
COUNTER-ROTATING	UP TO 600HP	HC5343	HH5271	5

CYLINDER PART #HC5343

To establish whether or not this cylinder is suitable for your application, the following points should be considered:

1. Fore and aft alignment of cylinder. If not mounted in line, motors will have a different turning radius.
2. Distance between motors.
3. Distance of travel in tilt arc.
4. Horizontal alignment of cylinder.

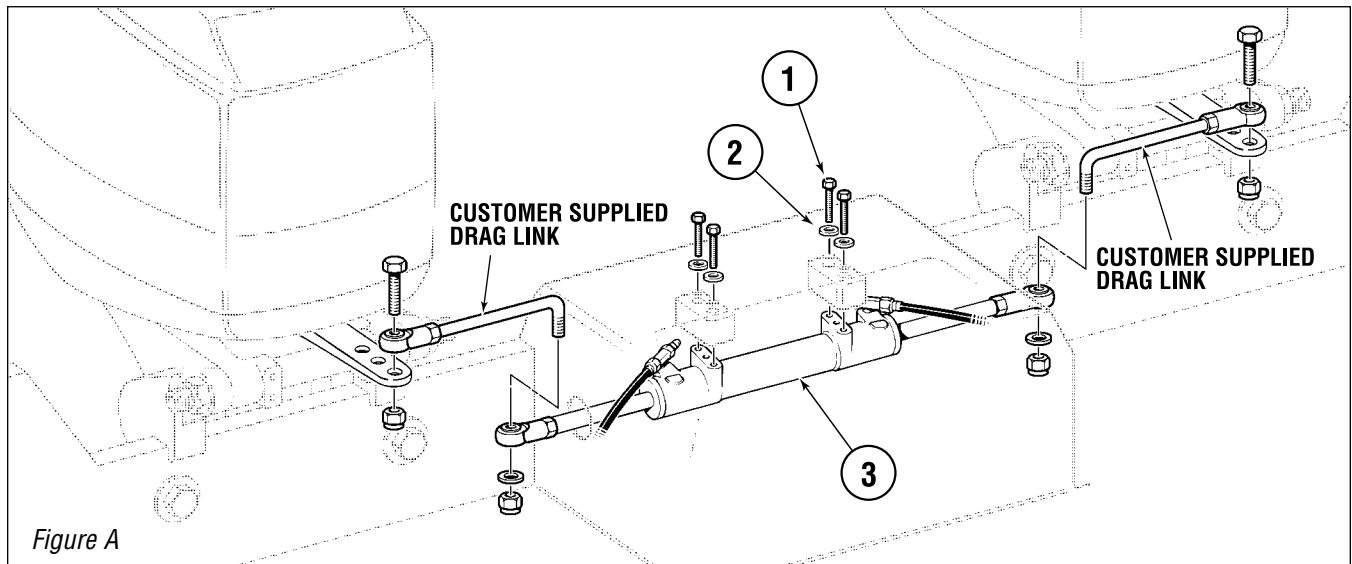

Figure A

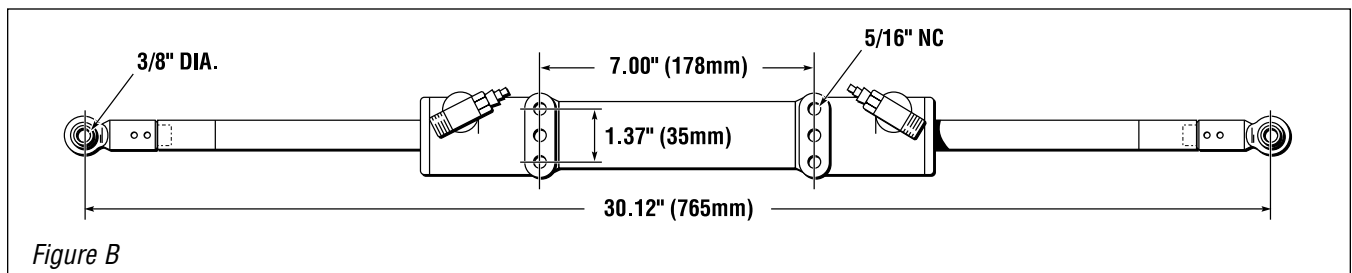

Figure B

ITEM	PART #	QTY	DESCRIPTION
1	799865	4	Screw HHCS 5/16" NC x 1" SS
2	010924	4	Washer 5/16" dia.
3	HC5343	1	Tandem Catamaran Steering Cylinder

Technical Information

Seal Replacement Kit Part # HS5157
 Cylinder Volume 8.13 cu. in. (133.2cc)
 Cylinder Stroke 10"
 Fittings 3/8" compression
 Threads 9/16" x 24 extra fine