

# TIE BAR KIT #H05081

Triple, Mercury/Mariner Outboard Engine.

ENGINE MANUFACTURER	YEAR	MODEL	CYLINDER	ENGINE TIE BAR KITS	NOTE
<b>MERCURY/MARINER</b>	1991-TO DATE	75-275 HP	HC5345 (2)	<b>H05081</b>	

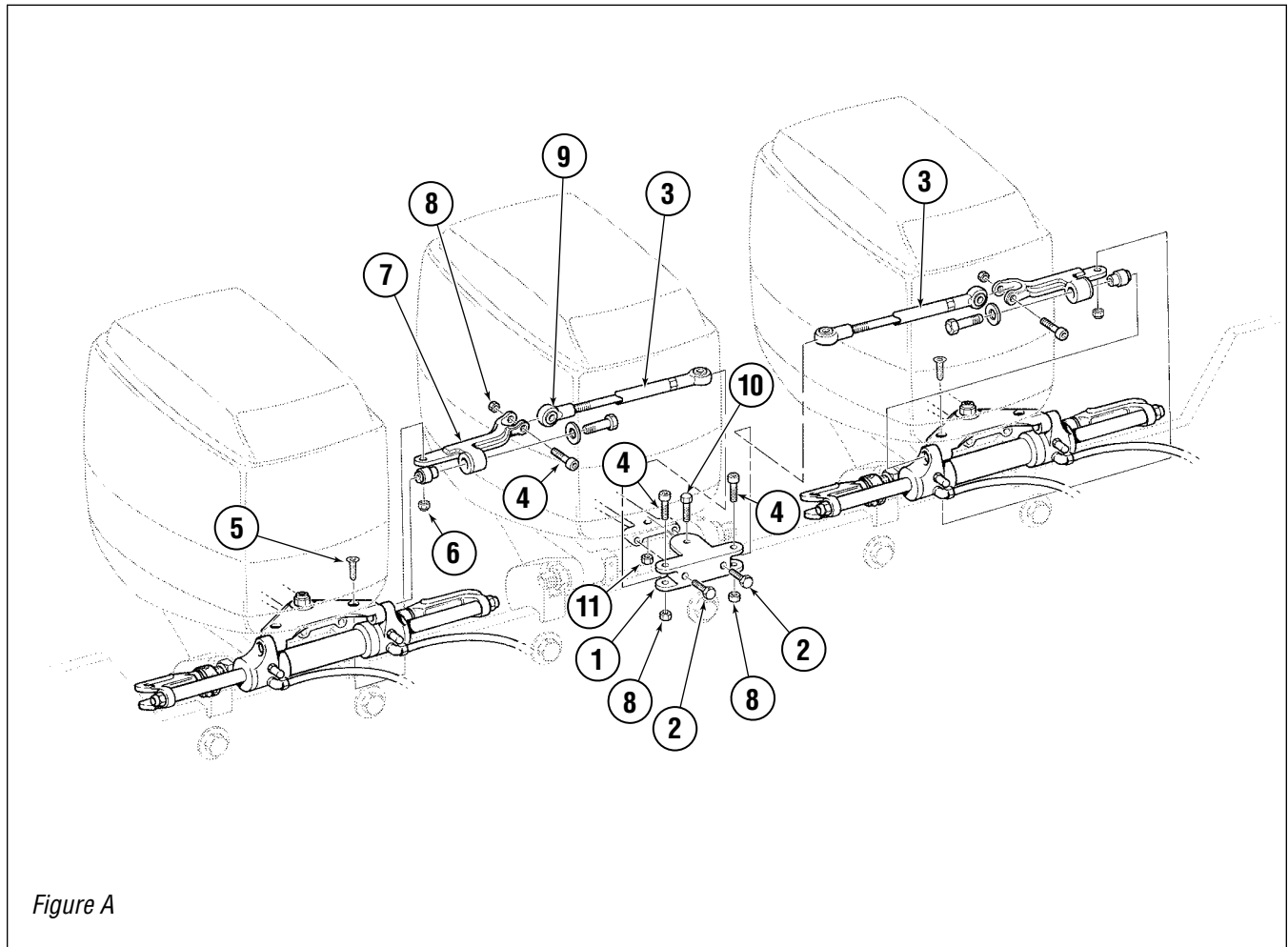

Figure A

ITEM	PART #	QTY	DESCRIPTION
1	741134	1	Bracket, Tiebar
2	750027	2	HHCS, 5/16" UNF x 1-1/2", SS, NLS
3	722543	2	Tie Bar
4	186540	4	3/8" x 1-1/4" Shoulder Bolt, SS
5	185901	2	FHCS, 5/16" NC x 7/8", SS
6	113021	2	Nut, 5/16" NC Nylok®, Thin, SS

ITEM	PART #	QTY	DESCRIPTION
7	961665	2	Drive Bracket Assembly
8	704525	4	5/16" NC Nylok® Nut, SS
9	116527	2	Rod End Ball 1/2", SS
10	113330	1	HHCS, 3/8" NF x 1-3/8", SS, FT
11	113529	1	Nut, 3/8" NF Nylok®, Thin, SS

# TIE BAR KIT #H05081

## Installation Instructions (Triple Engine)

### New Style Tie Bar

#### ⚠ WARNING

Refer to page 7 of SeaStar Book 1.1 for important warnings and information regarding the correct installation of your SeaStar hydraulic hose.

Cut the threaded end of the tie bar and tube to length using the following formulas below:

**⚠ CAUTION** The CD dimension must include allowance for engine toe in/out as required, or recommended by the engine manufacturer. Failing to observe toe in/out recommendations may result in harder than normal steering effort.

#### ⚠ WARNING

At the time of installation and any other time thereafter, the threaded rod must always fully cover inspection hole 1 of the rod end, but never inspection hole 2. Failing to observe this warning may result in one engine becoming separated from the steering system resulting in property damage and/or personal injury. The SeaStar tie bar is designed for use on Teleflex/SeaStar cylinders only. It may not be compatible with other cylinders.

**Note:** Maximum standard engine center = 3ft. (0.9m)

## H05081

X=CD - 12.125

Y=CD - 15.125

**Note:** H05081 Minimum Engine centers = 24" (610mm)

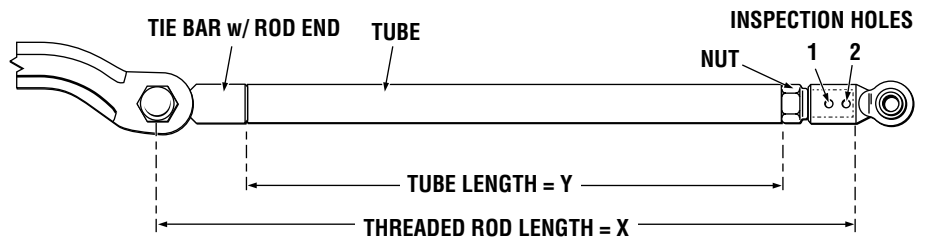

#### ⚠ CAUTION

Ensure that each cylinder is allowed to hit it's piston stop. The tie-bar may have to be disconnected. Failure to do so may fail to purge all the air from the system, causing poor performance.