

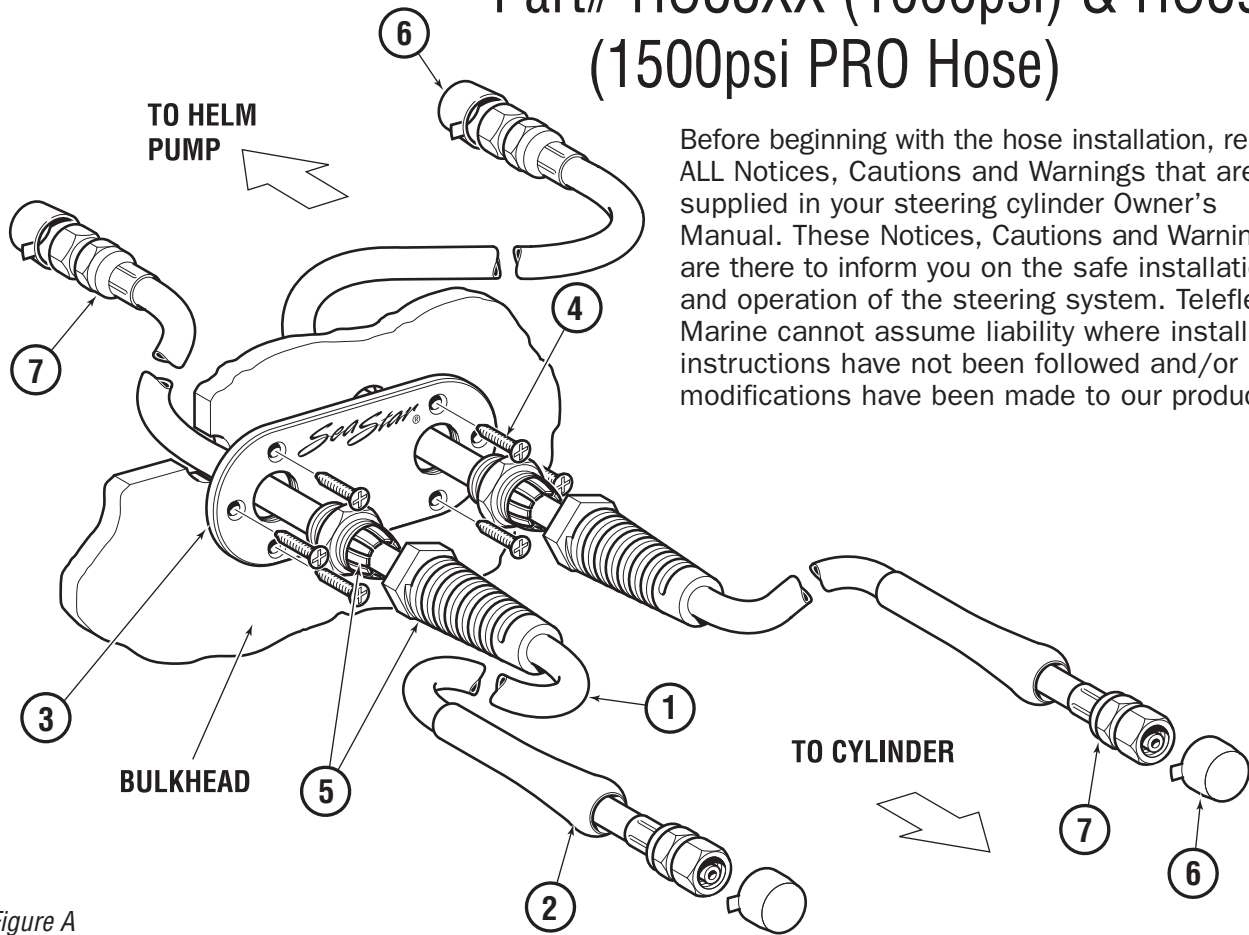

POLISHED BULKHEAD DUAL HOSE KITS

Part# H088XX (1000psi) & H089XX (1500psi PRO Hose)



Before beginning with the hose installation, read ALL Notices, Cautions and Warnings that are supplied in your steering cylinder Owner's Manual. These Notices, Cautions and Warnings are there to inform you on the safe installation and operation of the steering system. Teleflex Marine cannot assume liability where installation instructions have not been followed and/or modifications have been made to our products.

Figure A

NOTICE

If spare parts are required an entire new length of hose will need to be ordered. There is no means to swage a new swage fitting (item 7) on to a hose in the field.

ITEM	QTY	DESCRIPTION
1	N/A	SeaStar Outboard Steering Hose Various lengths. DO NOT cut.
2	2	Bend Restrictor. Not available for purchase as a separate item
3	1	Polished Bulkhead Mounting Plate, DUAL
4	6	#10 Screws (Customer Supplied)

ITEM	QTY	DESCRIPTION
5	2	Pigtail Fitting. Not available for purchase as a separate item
6	4	Dust Cap, Red Dust Cap, Green
7	4	Swage Fitting. Not available for purchase as a separate item

Installation Instructions

- Determine desired area where the hoses will exit the transom. DO NOT mount below the waterline of the boat as this is NOT a fluid tight fitting.

NOTICE

Ensure that the plate will be mounted to a flat, even surface.

- Drill two, 1" holes at 3" center to center (refer to figure B below) through the bulkhead/splashwell. Clean holes after drilling to ensure they are free of any burrs that may puncture or chafe the steering hoses.
- Feed hoses (item 1) from the outside, through the bulkhead/splashwell, inside along gunwale/PVC Tubing, under deck and to the helm pump. The bend restrictors (item 2) are to be installed onto the steering cylinder(s).

CAUTION

DO NOT remove the protective caps from the steering hoses until connection to the helm(s) and cylinder(s) are ready to be made.

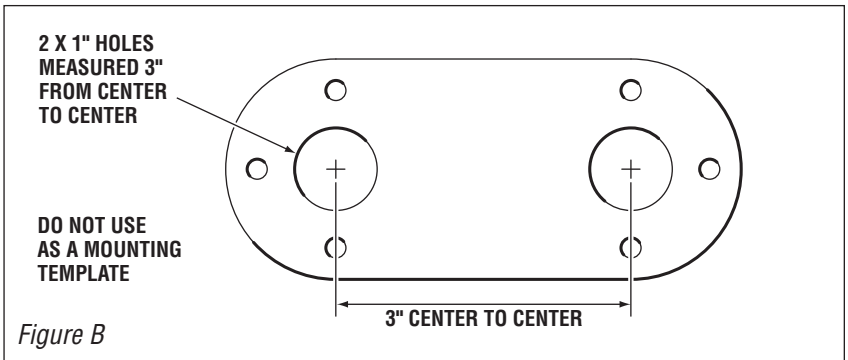

Figure B

- Secure the bulkhead mounting plate (item 3) to the outside of the Splashwell using six #10 screws (item 4, customer supplied).
- Secure hydraulic hoses to the steering cylinders and slide the bend restrictor (item 2) over the swage fitting. Torque fitting (item 7) to 15 ft.lb. (20.34Nm).
- Thread the pigtail fittings (item 5) onto the bulkhead mounting plate (item 3).

CAUTION

Ensure that there is sufficient hose to allow full engine movement in ALL Trim/Tilt and steering ranges.

- Torque pigtail fitting to 20 in.lb. (2.31 Nm).

WARNING

DO NOT mount below static float plane of boat. This is not a fluid tight fitting.

WARNING

DO NOT cut SeaStar Outboard steering hose. There is no means in the field to install a swage fitting to the hose end.

NOTICE

Individual items (i.e. swage fitting, plate, hose, etc.) cannot be ordered as a single part. If replacement parts are required an entire new length of hose will need to be purchased.